

RECESSED VENT FOR SUPPLY AND EXHAUST AIR

DESCRIPTION

- Recessed vent for supply and exhaust air, for flexible use in all interior spaces
- Flush, recessed installation in ceilings and walls; comes with mounting bracket and cardboard guard against construction site dust
- 100 percent free cross section for DN 100 air ducts
- Combination option with tecanno inserts for air regulation and filtration
- Flush cover guarantees unchanging design
- Symmetrical, flow-optimised passage of air
- Protected design patent, made in Germany
- Made of sheet steel with electrostatic powder coating (RAL colour 9016-20, layer thickness approx. 60 µm)

TECHNICAL DATA

Manufacturer	Tecanno
Type	Vent ONE PLUS 100
Dimensions L x W x H (mm)	160 x 160 x 30
Connecting Piece ø (mm)	99
Weight (g)	493
Material	Sheet steel with electrostatic powder coating
Standard RAL colour	9016-20 layer thickness approx. 60 µm
Item No.	0101100-9016-20

ACCESSORIES	VOLUME FLOW REGULATOR	FILTER INSERT	REPLACEMENT FILTER (5 x)
Item No.	10100	20100	30100

Accessories, if required, must be ordered separately.



Front view

Back view

Side view

TENDER SPECIFICATION

Tecanno air vent ONE PLUS 100 for supply and exhaust air in design-type construction. For installation in ceilings and walls via 100 mm connecting pieces. 100 percent freely usable cross section. Can be combined with VOLUME FLOW REGULATOR or FILTER INSERT from Tecanno. The flush cover ensures a consistently slim design with a symmetrical, flow-optimized air throughput. Vent made of sheet steel with electrostatic powder coating (RAL 9016-20). Made in Germany. Registered design patent.

Manufacturer: Tecanno

Type: Vent ONE PLUS 100

Dimensions L x W x H (mm): 160 x 160 x 30

Item No.: 0101100-9016-20

CONFIGURATION

The air vent has a 100 percent freely usable cross-section that accepts a VOLUME FLOW REGULATOR or FILTER INSERT. The VOLUME FLOW REGULATOR can be combined with a filter. Adding a VOLUME FLOW REGULATOR to the air vent allows the air flow rate to be regulated. This facilitates a variety of acoustic data and pressure reductions. For exhaust air filtration, the FILTER INSERT is ideal. The accessories can be inserted into the vent connecting piece separately. The flush cover hides the system and ensures a consistently slim design.



FILTER INSERT 100

VOLUME FLOW REGULATOR 100

ACCESSORIES

To supplement the air vents, we provide inserts for air regulation or air filtration.

- VOLUME FLOW REGULATOR: For supply or exhaust air. The VOLUME FLOW REGULATOR for air regulation can be combined with a filter (Item: REPLACEMENT FILTER) to allow exhaust air regulation.
- FILTER INSERT: For exhaust air. FILTER INSERT cannot be regulated.
- REPLACEMENT FILTER: 5 filters for use in the VOLUME FLOW REGULATOR or FILTER INSERT.

More information under »Acoustic data and pressure reductions« and on the relevant accessories' data sheets.

ORDERING INFORMATION

Air vent: Vent ONE PLUS 100

(Item No. 0101100-9016-20)

Accessories*: VOLUME FLOW REGULATOR 100

(Item No. 10100) or

FILTER INSERT 100 (Item No. 20100)

* The accessory (VOLUME FLOW REGULATOR and FILTER INSERT) is not included in the scope of delivery. Accessories, if required, must be ordered separately.

→ ACOUSTIC DATA AND PRESSURE REDUCTIONS
VENT ONE PLUS 100

DEFINITIONS

Vol in m³/h: Volume flow rate per air vent
 α: Volume flow regulator opening degree in %
 Δp in Pa: Total pressure loss
 L_{WA} in dB(A): A-weighted sound power level

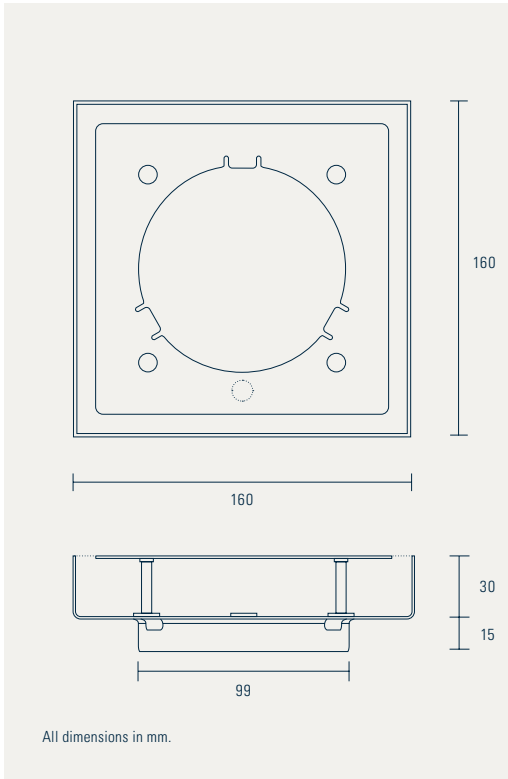

SOUND POWER LEVEL/PRESSURE REDUCTION

The flow rate is set by turning the volume flow regulator (α = degree of opening), which can be inserted into the vent connecting piece as required. Alternatively, the filter insert serves as a dust filter. Without any insert, the valve has a freely usable cross section. The volume flow regulator can be combined with a filter.

With volume flow regulator

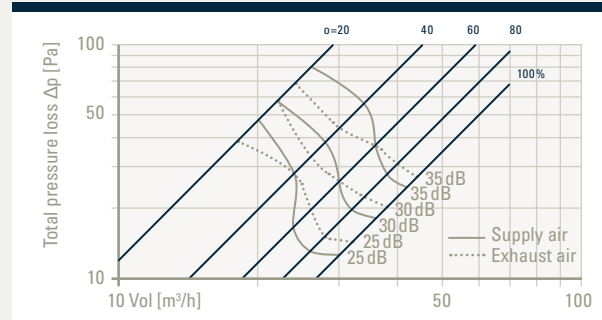

With filter insert/without insert

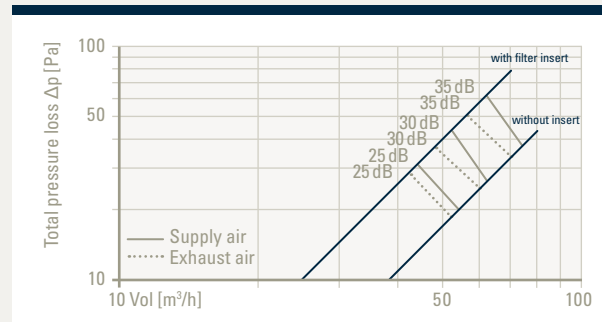

With volume flow regulator and filter

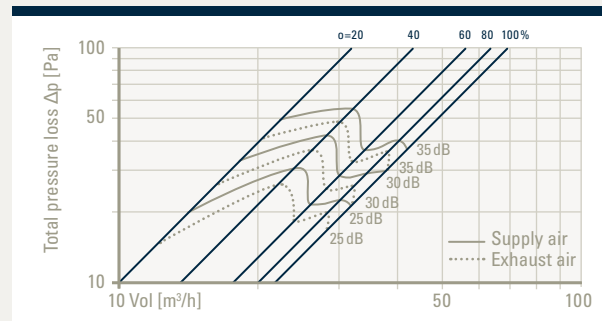

TRAJECTORY LENGTH

The trajectory length $l_{0,2}$ displayed in the diagram indicates the distance between outlet and the point in the air current (Isotherm) at which the speed drops to 0.2 m/s.

Recommended installation for supply air: Ceiling installation: 0.5 m distance from both sides of corner to vent edges. Wall installation: 0.1 m distance from both sides of corner to vent edges. For exhaust air, no minimum distances.

With volume flow regulator

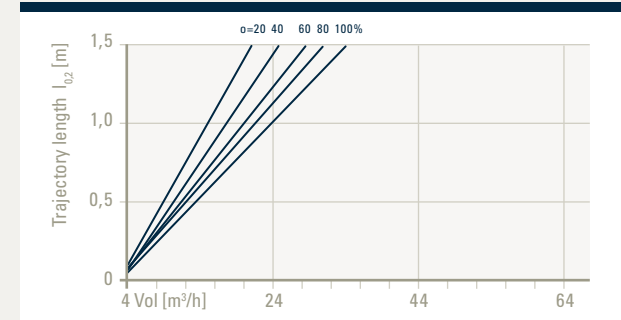

With filter insert/without insert

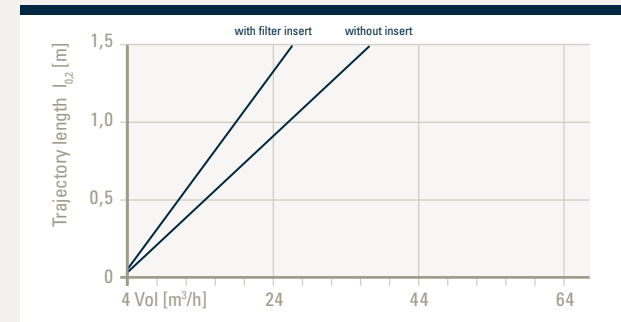

With volume flow regulator and filter

